

# A3 MINI

## User Manual

V1.0 Nov, 2021 Revision



Thank you for purchasing our products. A3 Mini is a high-performance and functional 6-axis mini gyro system designed for R/C airplanes. The smaller size and more compact design make it more suitable for the small electric airplanes. With the new feature of multi-protocol serial receiver support, it could be compatible with most single line mini receivers on the market. In order for you to make the best use of your gyro and to fly safely, please read this manual carefully and set up the device as described below.

## IMPORTANT NOTES



Radio controlled (R/C) models are not toys! The propellers rotate at high speed and pose potential risk. They may cause severe injury due to improper usage. It is necessary to observe common safety rules for R/C models and the local law. Read the following instructions thoroughly before the first use of your gyros and setup the gyro carefully according to this manual. We also recommend that you seek the assistance of an experienced pilot before attempting to fly with our gyros for the first time.



After power on, A3 Mini needs to perform an accurate gyroscope calibration, keep the airplane stationary after power on and wait while the LED flashes blue. The LED will stay solid blue if a slight movement is detected and the calibration will not start until you stop moving the airplane, however, making the airplane level is NOT required during the initialization.



A stick centering is also required following the gyroscope calibration. Always put all the sticks center (the throttle stick in the lowest position) before power on the airplane, and do not move the sticks until the initialization is done.



Make sure to check the gyro direction of Aileron, Elevator and Rudder channels after installation and always perform a test of them before each flight. An opposite reaction of the gyro could lead to losing control or even crash!

# INSTALLATION

## ⚠ NOTES

- Never use the hot-melt glue or nylon ties to fix the gyro onto the airplane!
- You need only one piece of the tapes each time, a soft or thick mounting may probably impact the performance of the gyro.
- The gyro is a sensing device, please make enough space around it and keep as far away from other electronic devices or wires as possible.

## MOUNTING ORIENTATION

Use one of the supplied double-sided tape to attach the gyro to your airplane firmly. For best performance, the gyro should be mounted as close to the C.G. as possible, and the housing edges must be aligned exactly parallel to all three rotation axes of the plane. The gyro can be attached flat or upright, and even upside down, however, you have to ensure the arrow on the sticker always point to the heading direction, otherwise the gyro will not work normally in ANGLE, LEVEL and HOVER modes.

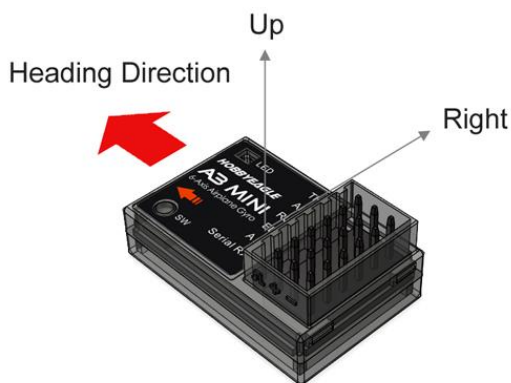

① Flat, face up

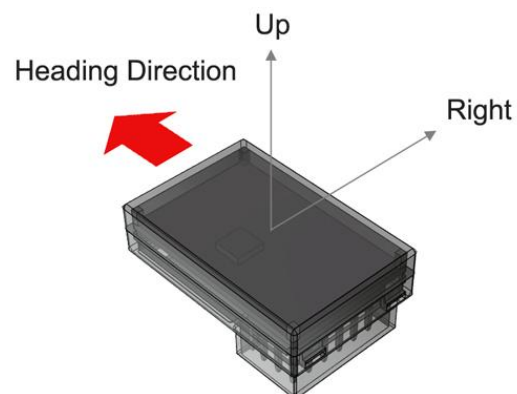

② Flat, face down

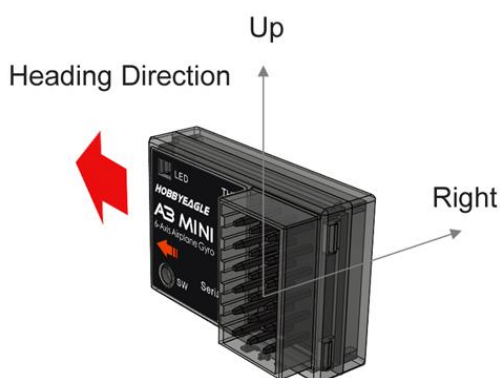

③ Upright, button down

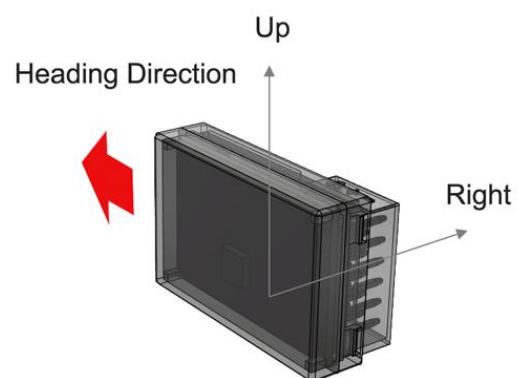

④ Upright Inverted, button up

# CONNECTION

## SINGLE-LINE RECEIVER CONNECTION

A3 Mini supports PPM and multi-protocol digital serial receivers which allows you to connect the receiver to [Serial RX] with only one single wire. Depending upon the protocol selected, A3 Mini will use the preset channel assignment to recognize the channels from the receiver. Refer to the table below and check if your radio transmits the channels in the correct order. Choose “None” for those channels you do not use.

**Table 1: Serial Receiver Protocols and Default Channel Assignment**

Serial Receiver Protocol	AIL	ELE	THR	RUD	MODE	GAIN
PPM Receiver	CH1	CH2	CH3	CH4	CH5	None
Futaba S.Bus (FrSky SBUS or WFLY WBUS)	CH1	CH2	CH3	CH4	CH5	None
Spektrum DSM/DSMX 1024 Satellite	CH2	CH3	CH1	CH4	CH5	None
Spektrum DSM/DSMX 2048 Satellite	CH2	CH3	CH1	CH4	CH5	None
Spektrum SRXL	CH2	CH3	CH1	CH4	CH5	None
Multiplex SRXL/JR XBUS Mode B	CH2	CH3	CH1	CH4	CH5	None
Graupner SUMD	CH2	CH3	CH1	CH4	CH5	None
FlySky iBUS	CH1	CH2	CH3	CH4	CH5	None

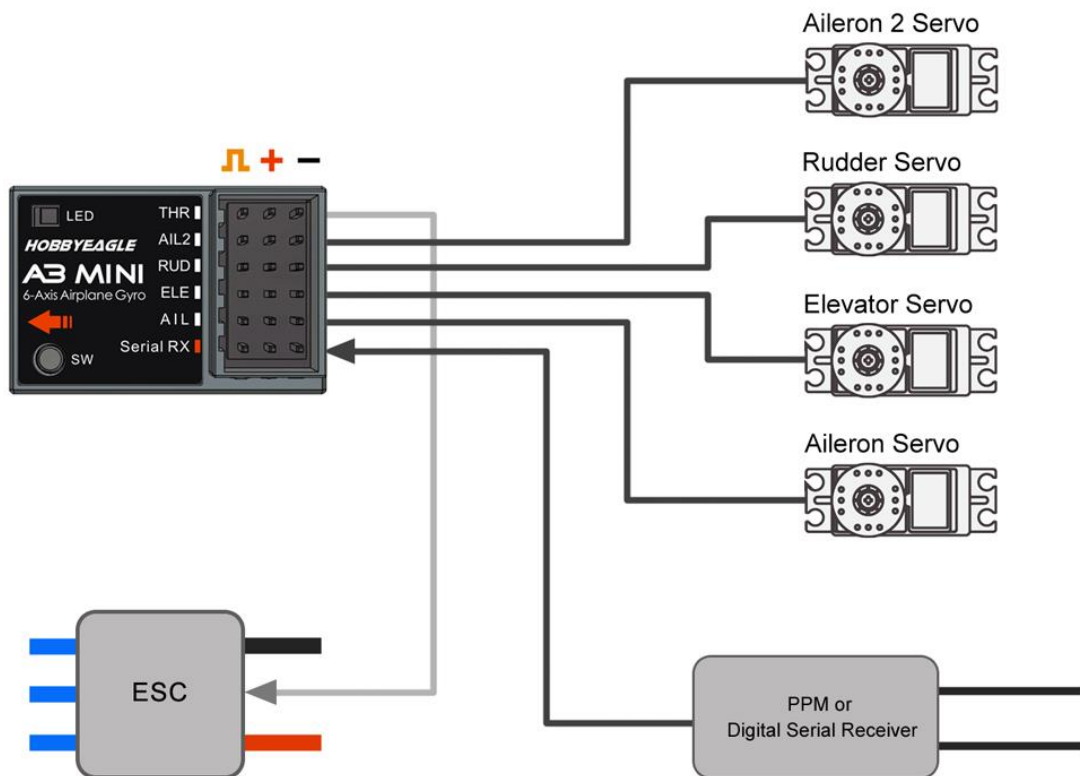

## NOTES

- Please note that the remote master gain channel is disabled as default. Assign a channel number for channel GAIN to activate this feature if you need.
- Pay attention to the polarity of the plugs. The Orange or White signal line must always be on the inner side of the gyro.
- You will need to purchase an optional adapter if you are using a Spektrum satellite receiver.

## SERVO CONNECTION

A3 Mini supports standard fixed-wing, flying-wing (Delta-wing) and V-tail. Connect the servos to the corresponding connectors by following the illustration below.

Standard Fixed-wing

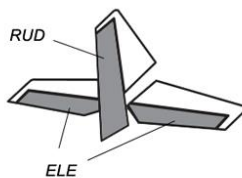
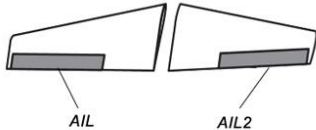

Flying-wing (Delta)

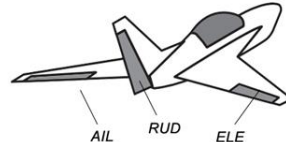

V-tail

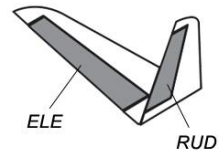

## NOTES

- Make sure that there are no mixing functions active on your transmitter. Have a look at the radio's servo monitor and verify that each stick controls only one output channel.
- Most flying-wings have no rudder, in this case, [RUD] is unnecessary to connect.

## FLIGHT MODES

A3 Mini provides 6 flight modes which can be switched by a 3-position switch of the transmitter during flight. The factory default mode allocation of the switch is **NORMAL - LEVEL - ANGLE**. The color of the LED shows the current flight mode of the gyro while in use.

**Table 2: Colors of the LED for flight modes**

	Solid Red	GYRO OFF Mode
	Solid Blue	NORMAL Mode
	Blue, Flashing	LOCK Mode
	Solid Violet	ANGLE Mode
	Violet, Flashing	LEVEL Mode
	Violet, Fast Flashing	HOVER Mode

## 1. GYRO OFF MODE

When operating in *GYRO OFF* mode the gyro will be deactivated completely, and the airplane will be completely under the control of your transmitter as it was before installing the gyro. This mode is usually used for testing purpose only.

## 2. NORMAL MODE

The *NORMAL* mode, also known as the '*Rate mode*', is the most basic function of the gyro. It works based on the rotation rate control of each axis of the airplane. When operating in this mode, the gyro will only correct currently occurring rotational movements, a momentary reaction will be applied to the servos when the airplane rotating on corresponding axis, after rotation the servos will move back to their neutral position as soon as the airplane standing still immediately. The *NORMAL* mode can be used with nearly any size and type of airplanes. It can effectively improve the stability and precision of the airplane and reduce the stall point specially.

## 3. LOCK MODE

The *LOCK* mode is also known as the '*Attitude Lock mode*', '*3D mode*' or '*AVCS mode*'. Different from *NORMAL* mode, the gyro will perform a permanent correction for rotational movements on each axis constantly. That is when you release the sticks the airplane will stop and lock its current position immediately. This mode is well suited for practicing basic 3D maneuvers such as hovering or knife edge. Since it can help you to lock the attitude of the airplane, it is also helpful for landing.

## 4. ANGLE MODE (FORMER TRAINER MODE)

The *ANGLE* mode, also known as the '*Trainer mode*' or '*Attitude mode*', will limit the maximum angle of the airplane on both roll and pitch axes. Roll and loop are not allowed in this mode, the airplane will be stabilized all the time, independent of any stick input. This prevents the airplane from being tilted into a larger angle that may cause a danger. As soon as the sticks are released, the airplane will be brought back to horizontal position automatically. You can use this mode as emergency rescue, or in other applications, e.g., to have a training for new beginners or to use for FPV. The maximum allowed angle can be set in the configurator. In addition, changing the stick rate can also affect the max tilt angle.

## 5. LEVEL MODE

The *LEVEL* mode is also known as the '*Auto-Level mode*', '*Auto-Balance mode*' or '*Horizon mode*'. When operating in this mode, the airplane will be brought to horizontal position automatically when releasing the sticks. Different from the *ANGLE* mode, there is no maximum angle limitation in this mode and the airplane will be stabilized only when there is no specific control input from aileron and elevator sticks. This mode can be used if the pilot becomes disoriented and would like to save the airplane from crashing.

## 6. HOVER MODE

The *HOVER* mode, also known as the '*Auto-Hover mode*', provides the same functionality as the *LEVEL* mode. The only difference is that when you release the sticks, the airplane will be brought to vertical position (nose up) and keeps hovering. This mode is designed to help you to learn hovering maneuver

and reduce the probability of crashing.

## GAIN ADJUSTMENT

### BASIC GAIN

Both the configurator and the program card provide basic gain settings for Aileron, Elevator and Rudder separately. Basic gain determines the momentary reaction strength of the gyro. In general, the higher the gain the harder the airplane will stop after rotation and the more stable and precise the airplane will fly. But if the gain is too high the airplane will tend to oscillate at high frequency on the corresponding axis. If too small, the operation and stability will not be so good and the airplane does not stop precisely and overshoots. The gyro will be deactivated completely if you set the basic gain to 0%.

For the first flight test it is recommended to start with a lower basic gain setting (e.g. 30%) and switch the gyro to *NORMAL* mode. In case the airplane starts to oscillate in flight then reduce the gain of the corresponding axis. If the control feels weak and imprecise and does not hold position when stopping then increase the gain, according to this approach, fine tune the basic gain until you get the best performance.

### MODE GAINS

Furthermore, the gains corresponding to each flight mode can also be setup separately, including the *Lock Gain*, *Angle Gain*, *Level Gain* and *Hover Gain*, these gains should be adjusted based on the basic gain and only work with the corresponding flight mode.

### REMOTE MASTER GAIN

A3 Mini also supports the remote master gain control. You can make a linear adjustment by using a volume or slide lever on your transmitter or make a 3-level gain selection using a 3-position switch. This function is optional, the master gain will always default to 100% if you do not connect it. Master gain will not affect the basic gain and flight mode gain settings on the gyro.

## GYRO DIRECTION

After installation, lift the airplane up and make it quickly rotate around the roll, pitch and yaw axes respectively. Make sure all the control surfaces react in the correct directions referring to the figures below.

### **VERY IMPORTANT!**

It is extremely important to make sure that the gyro reacts in the correct direction for each channel before flight. An opposite reaction of the gyro could lead to losing control or even crash!

### Check the gyro direction for Aileron

Quickly move the right wing downward around the roll axis, the right aileron surface should flap down and the left flap up as shown below.

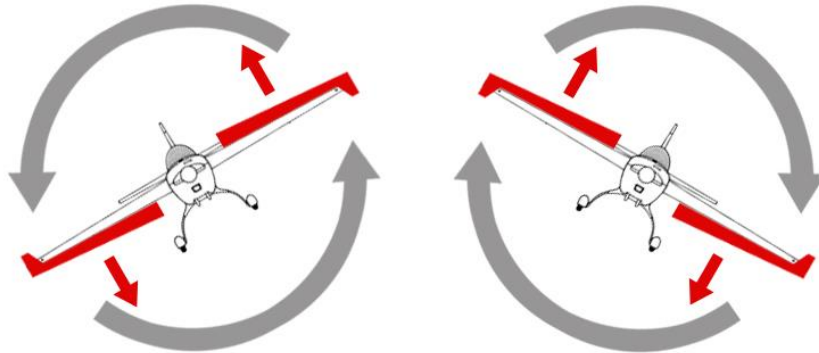

### Check the gyro direction for Elevator

Quickly move the nose of the airplane downward around the pitch axis, the elevator surface should flap up as shown below.

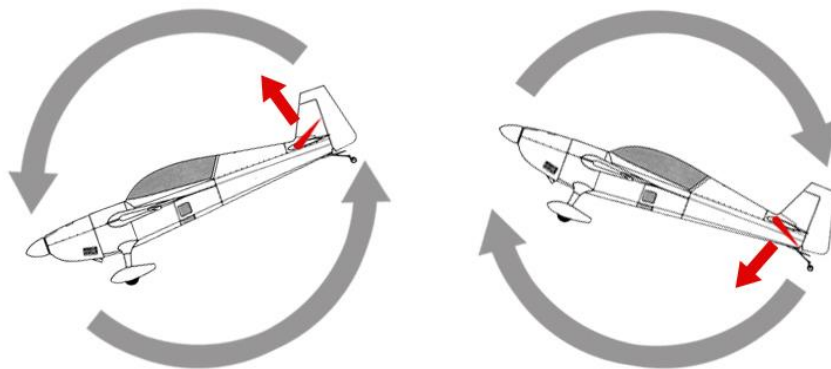

### Check the gyro direction for Rudder

Quickly move the nose of the airplane to the left around the yaw axis, the rudder surface should flap right as shown below.

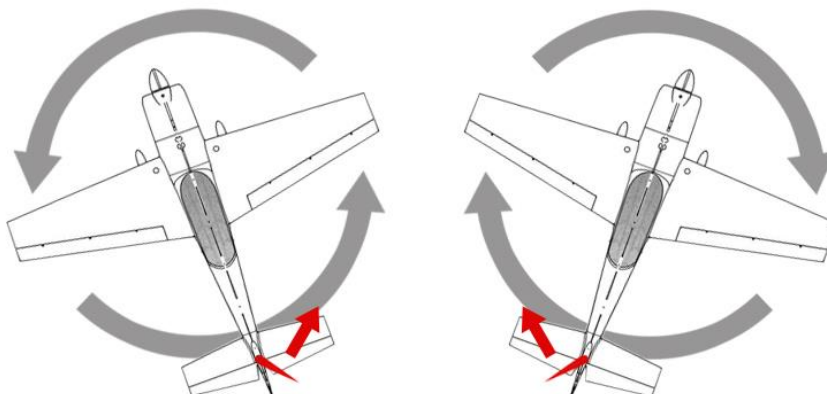



## QUICK GYRO REVERSING

A3 Mini also provides you a quick approach to reverse the gyro direction without connecting it to a PC or a programming card. For example, to reverse the gyro direction of Aileron, press and hold the button while moving and holding the Aileron stick right or left for about 2 seconds, release both the button and the stick when the LED flashes White once, indicating that the gyro direction of Aileron has been reversed and saved. Similarly, move the Elevator stick up or down for Elevator channel and move the Rudder stick right or left for Rudder channel while long pressing the button until the LED starts to flash White once.

## LEVEL AND HOVER CALIBRATION

When flying in *ANGLE* mode or *LEVEL* mode, A3 Mini needs to know the angle of the airplane in both roll and pitch directions, this is achieved by calculating the attitude of its own. A small angle deviation caused by installation can lead to an unexpected behavior when flying in *ANGLE* mode or *LEVEL* mode. For this reason, a level calibration is recommended to offset the error caused by installation and to establish a proper level reference of your airplane after installing the gyro.

### Step 1

Before calibrating, the airplane should be placed on the horizontal ground and make the wing parallel to the ground. Make the airplane slightly nose-up because a certain elevation angle is usually required to maintain level flight for most airplanes.

### Step 2

Click the "Level Calibration" button on the Sensor tab of the configurator to start the calibration. The whole calibration process will take you several seconds and the LED will blink Blue rapidly during calibrating. Do not move the airplane until the calibration is done.

### Step 3

After a successful calibration, the result will be saved and displayed on the screen, you can adjust them manually in the future. If you get a rapid Red blinking during calibration, this means the result exceeds the maximum permissible value (i.e.  $\pm 25\text{deg}$ ), in this case, you have to re-install the gyro to reduce the deviation caused by installation.

As a same reason, a hover calibration is recommended to perform after installation if you want to fly with *HOVER* mode. The procedure is quite similar to that of level calibration. The only difference is that the airplane should be lifted vertically to the ground instead of putting it on the ground in Step 1.

**TIP:** In Step 2, press and hold the button for about 2 seconds, release the button once the LED turns solid White can quickly perform a level calibration, similarly, press and hold the button more than 4 seconds until the LED starts to flash White continuously can quickly start a hover calibration.

## PROGRAMMING



Please download the *HobbyEagle A3 Configurator* and the *USB driver installer* from our website: <https://www.hobbyeagle.com/a3-configurator/>.

- The software supports Windows XP, Windows 7, Windows 8 and Windows 10 (32 or 64 bit).
- If the installation fails, please download and install *Microsoft .NET Framework 4* first.
- Install the USB driver before connecting the gyro to the PC.

## NOTES

- Always use the included USB adapter and the black data cable to connect the gyro to the PC or the programming card. NEVER use the common USB cables those for mobile phones or other products on the market with our gyro, this will cause the connection to fail.
- It is recommended to use the new *Program Card X* for A3 Mini, please upgrade the card to the latest version using the *A3 Configurator*.
- If you are using an old program card, please limit the working voltage of the gyro to 5.5V, otherwise, the program card may get damaged!

## SPECIFICATIONS

<b>Main Controller:</b>	32-bit MCU
<b>Sensors:</b>	High-precision 3-axis gyroscope and 3-axis accelerometer
<b>Gyroscope Scale Range:</b>	± 2000dps
<b>Accelerometer Scale Range:</b>	± 4g
<b>PWM:</b>	800uS - 2220uS, Neutral 1500/1520uS, 50Hz - 333Hz
<b>Input Voltage:</b>	DC 3.6V - 8.4V
<b>Operating Temperature:</b>	-10°C - 50°C
<b>Size:</b>	30 × 19.5 × 7.5mm
<b>Weight:</b>	4.8g (excluding wires)